

## European Technical Assessment

**ETA 16/0771**  
of 30.07.2019



### General part

#### Technical Assessment Body issuing the ETA: ITeC

ITeC has been designated according to Article 29 of Regulation (EU) No 305/2011 and is member of EOTA (European Organisation for Technical Assessment).

<b>Trade name of the construction product</b>	<b>AF Multicollar</b>
<b>Product family to which the construction product belongs</b>	Fire stopping and fire sealing products. Penetration seals.
<b>Manufacturer</b>	<b>AF SYSTEMS SRL</b> Via Edward Jenner 41-43 IT-26837 Mulazzano Italy
<b>Manufacturing plant(s)</b>	According to Annex N kept by ITeC.
<b>This European Technical Assessment contains</b>	32 pages including 2 Annexes which form an integral part of this assessment  and  Annex N, which contains confidential information and is not included in the European Technical Assessment when that assessment is publicly available.
<b>This European Technical Assessment is issued in accordance with Regulation (EU) 305/2011, on the basis of</b>	European Assessment Document EAD 350454-00-1104.
<b>This version replaces</b>	ETA 16/0771, issued on 21.12.2016.

**General comments**

Translations of this European Technical Assessment in other languages shall fully correspond to the original issued document.

Communication of this European Technical Assessment, including transmission by electronic means, shall be in full (excepted the confidential Annex(es)).

## Specific parts of the European Technical Assessment

### 1 Technical description of the product

AF Multicollar is a services closure device used as fire penetration seal, consisting of a fire protective inlay made of intumescent material contained in a housing of stainless steel with flanges for fixing to the constructive element.

AF Multicollar is supplied in one size only and cut to a length to suit the external diameter of the service to be protected. The detailed technical specification of AF Multicollar and the description of the installation procedure are given in Annex A.

Assembled penetration seals require additional components as described in Annex B. These components cannot be CE marked based on this ETA.

### 2 Specification of the intended use(s) in accordance with the applicable EAD

AF Multicollar is used to reinstate the resistance to fire performance of flexible or rigid wall and rigid floor constructions where they are penetrated by services (combustible pipes, insulated metal pipes, multilayer composite pipes and cables). The detailed specification of the services that may be protected with AF Multicollar is given in Annex B.

The specific elements of construction where AF Multicollar may be used to provide a penetration seal in, are as follows unless otherwise specified in Annex B:

- Flexible walls: Walls with a minimum thickness of 120 mm, which comprise timber or steel studs lined on both faces with minimum two layers of 12,5 mm thick 'Type F' or 'Type DF' gypsum plasterboards according to EN 520<sup>1</sup>. In timber stud walls, no part of the penetration shall be closer than 100 mm to a stud, the cavity must be closed between the penetration seal and the stud and minimum 100 mm of insulation of reaction to fire class A1 or A2, according to EN 13501-1, is provided within the cavity between the penetration seal and the stud.
- Rigid walls: Concrete or masonry walls with a minimum thickness of 120 mm and a minimum density of 500 kg/m<sup>3</sup>.
- Rigid floors: Aerated concrete or other type of rigid floors with a minimum thickness of 150 mm and a minimum density of 550 kg/m<sup>3</sup>.

The constructive element where the collars are installed must be classified in accordance with EN 13501-2<sup>2</sup> for the required fire resistance period.

---

<sup>1</sup> EN 520 Gypsum plasterboards. Definitions, requirements and test methods.

<sup>2</sup> EN 13501-2 Fire classification of construction products and building elements. Part 2: Classification using data from fire resistance tests, excluding ventilation services.

AF Multicollar is intended for environmental conditions as defined for use category Type Y<sub>2,(-20/70)°C</sub> according to EAD 350454-00-1104: intended for semi-exposed use at temperatures below 0°C, but with no exposure to rain nor UV. Type Y<sub>2,(-20/70)°C</sub> includes lower use categories (i.e. Type Z<sub>1</sub> and Type Z<sub>2</sub>).

The provisions made in this ETA are based on a working life of AF Multicollar of at least 10 years, provided that the conditions laid down in the manufacturer's instructions for the installation, use and maintenance are met. These provisions are based upon the current state of the art and the available knowledge and experience.

The indications given as to the working life of the product cannot be interpreted as a guarantee but are regarded only as a means for choosing the appropriate products in relation to the expected economically reasonable working life of the works.

### 3 Performance of the product and reference to the methods used for its assessment

#### 3.1 Performance of the product

The assessment of AF Multicollar has been performed in accordance with EAD 350454-00-1104 for *Penetration Seals (September 2017)*.

**Table 1:** Performance of the product.

Product: AF Multicollar		Intended use: Fire penetration seal	
Basic requirement	Essential characteristic		Performance
BWR 2 Safety in case of fire	Reaction to fire	Inlay material	E
		Steel housing	A1
	Resistance to fire	See Annex B	
BWR 4 Safety and accessibility in use	Durability		Type Y <sub>2,(-20/70)°C</sub>

The rest of characteristics included in EAD 350454-00-1104 have not been assessed in this ETA.

## 3.2 Methods used for the assessment

### 3.2.1 Reaction to fire

The performance of the inlay material of AF Multicollar has been tested according to EN ISO 11925-2<sup>3</sup> and determined according to EN 13501-1<sup>4</sup> and Regulation (EU) 2016/364.

The collar housing made of stainless steel has a class A1 according to Decision 96/603/EC and Decision 2000/605/EC.

### 3.2.2 Fire resistance

Tested and assessed according to EN 1366-3<sup>5</sup>, the fire resistance classification has been determined according to EN 13501-2 and is given in Annex B.

### 3.2.3 Durability

AF Multicollar has been tested and assessed for the environmental use category Type Y<sub>2</sub>, (-20/70)°C in accordance with section 2.2.9 of EAD 350454-00-1104 and the EOTA Technical Report 024<sup>6</sup>, section 4.2.5, table 4.1.

Stainless steel in accordance with EN 10088-1<sup>7</sup> is intended for use category Type Y<sub>2</sub>, (-20/70)°C.

## 4 Assessment and verification of constancy of performance (AVCP) system applied, with reference to its legal base

According to the Decision 1999/454/EC of the European Commission, the system of AVCP (see EC delegated Regulation (EU) No 568/2014 amending Annex V to Regulation (EU) 305/2011) given in the following table applies.

**Table 2:** AVCP System.

Product(s)	Intended use(s)	Level(s) or class(es)	System(s)
Fire stopping and fire sealing products	For fire compartmentation and/or fire protection or fire performance	Any	1

<sup>3</sup> EN ISO 11925-2 Reaction to fire tests. Ignitability of products subjected to direct impingement of flame. Part 2: Single-flame source test.

<sup>4</sup> EN 13501-1 Fire classification of construction products and building elements. Part 1: Classification using data from reaction to fire tests.

<sup>5</sup> EN 1366-3 Fire resistance tests for service installations. Part 3: Penetration seals (2009).

<sup>6</sup> TR 024 Characterisation, Aspects of Durability and Factory Production Control for Reactive Materials, Components and Products, Edition July 2009.

<sup>7</sup> EN 10088-1 Stainless steels. Part 1: List of stainless steels.

## 5 Technical details necessary for the implementation of the AVCP system, as foreseen in the applicable EAD

All the necessary technical details for the implementation of the AVCP system are laid down in the *Control Plan* deposited with the ITeC and agreed in accordance with EAD 350454-00-1104, section 3.

The *Control Plan* is a confidential part of the ETA and only handed over to the notified product certification body involved in the assessment and verification of constancy of performance.

The factory production control operated by the manufacturer shall be in accordance with the above mentioned *Control Plan*.

Issued in Barcelona on 30 July 2019  
by the Catalonia Institute of Construction Technology.



Ferran Bermejo Nualart  
Technical Director, ITeC

## ANNEX A. Description of the product and installation process

### A.1. AF Multicollar components

AF Multicollar is made of the components described in table A.1 and supplied in one size only. The collar is cut to a length to suit the overall circumference of the protected service in accordance with table A.2. The intumescent strip is manufactured at a nominal thickness of 4 mm and the total intumescent thickness of every collar size (b in table A.2) is achieved by adding the required number of intumescent strip layers.

**Table A.1:** Components of AF Multicollar.

Part	Material	Dimensions
Collar housing	Stainless steel AISI 430 (1.4016) According to EN 10088-1	Thickness: 0,6 mm Length: 2500 mm Width: 50 mm
Inlay	Intumescent material	Thickness: 4 mm Length: 8600 mm Width: 50 mm

The collar housing sheet has transversal slots to allow the cutting to size according to the service diameter and the necessary length for wrapping around, as well as fixing flanges to install the collar. Dimensions are giving in figure A.1.

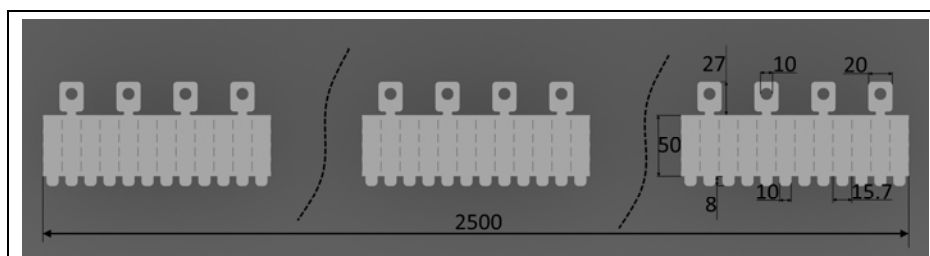

**Figure A.1:** Collar housing sheet.

### A.2. AF Multicollar dimensions

AF Multicollar is cut to suit the external diameter of the service to be protected (d in table A.2). The corresponding resistance to fire performance is given in Annex B, depending on the construction elements penetrated by the service and the penetration characteristics.

The AF Multicollar types covered by this ETA are given in table A.2.

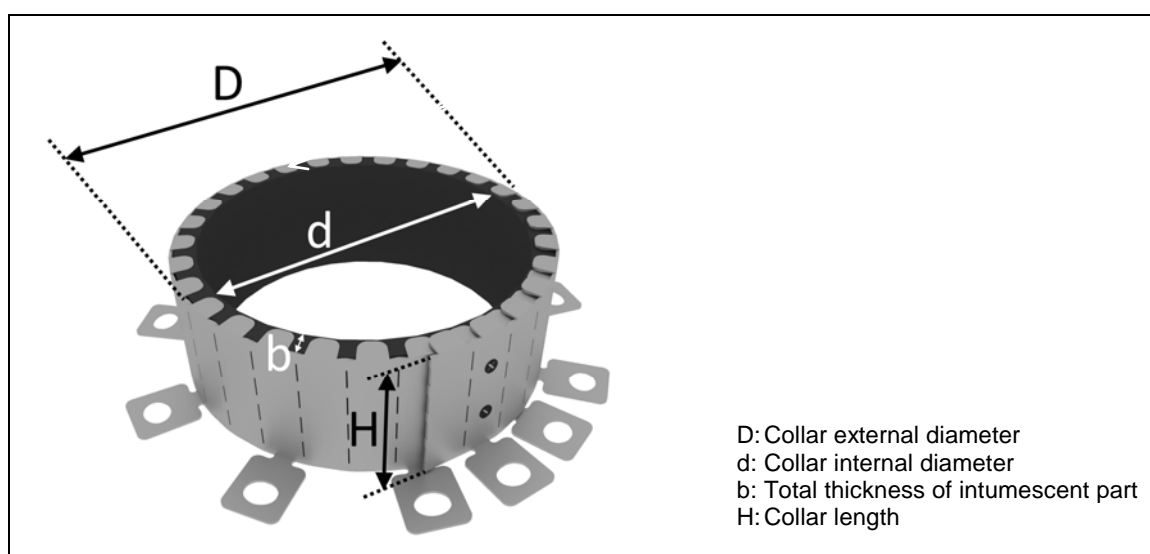

Figure A.2: Dimensions of AF Multicollar (installed).

Table A.2: Dimensions of AF Multicollar (installed).

Type	d (mm)	D (mm)	H (mm)	b (mm)	N° of strip layers	N° of fixings	Housing length (mm)	Inlay strip length (mm)
AF Multicollar 30	30	47	50	8	2	4	200	240
AF Multicollar 40	40	67	50	8	2	4	230	310
AF Multicollar 50	50	77	50	8	2	4	260	380
AF Multicollar 63	63	80	50	8	2	4	300	460
AF Multicollar 80	80	97	50	8	2	4	350	560
AF Multicollar 90	90	107	50	8	2	4	380	620
AF Multicollar 100	100	117	50	8	2	4	410	680
AF Multicollar 110	110	127	50	8	2	4	440	750
AF Multicollar 125	125	150	50	12	3	5	515	1310
AF Multicollar 140	140	165	50	12	3	5	560	1450
AF Multicollar 160	160	185	50	12	3	5	620	1640
AF Multicollar 200	200	241	100	20	5	5	2 x 795	2 x 3500
AF Multicollar 250	250	291	100	20	5	5	2 x 955	2 x 4300

Notes:

- d, D, H and b refer to the dimensions of the collar once installed (see figure A.2).
- Housing length and inlay strip length refer to the dimensions of the components to be cut for installation.
- For a service diameter higher than 160 mm, two adjacent AF Multicollar are installed as described in section A.3 for a total length (H) of 100 mm.
- For service diameters not given in this table, other sizes of AF Multicollar can be used, within the service diameter ranges given in the relevant table of Annex B, provided that the parameters H and b, as well as the number of fixings, are kept in accordance with the next greater size of AF Multicollar as showed in this table.
- For dimensions of AF Multicollar for sealing of insulated metal pipes, see section B.5.



### A.3. AF Multicollar installation

AF Multicollar will be installed in accordance with the manufacturer instructions and the provisions established in this section and in the relevant sections of Annex B. The sequence of installation is described in figure A.3. Installation requirements shall be fully met to achieve the performance given in Annex B.

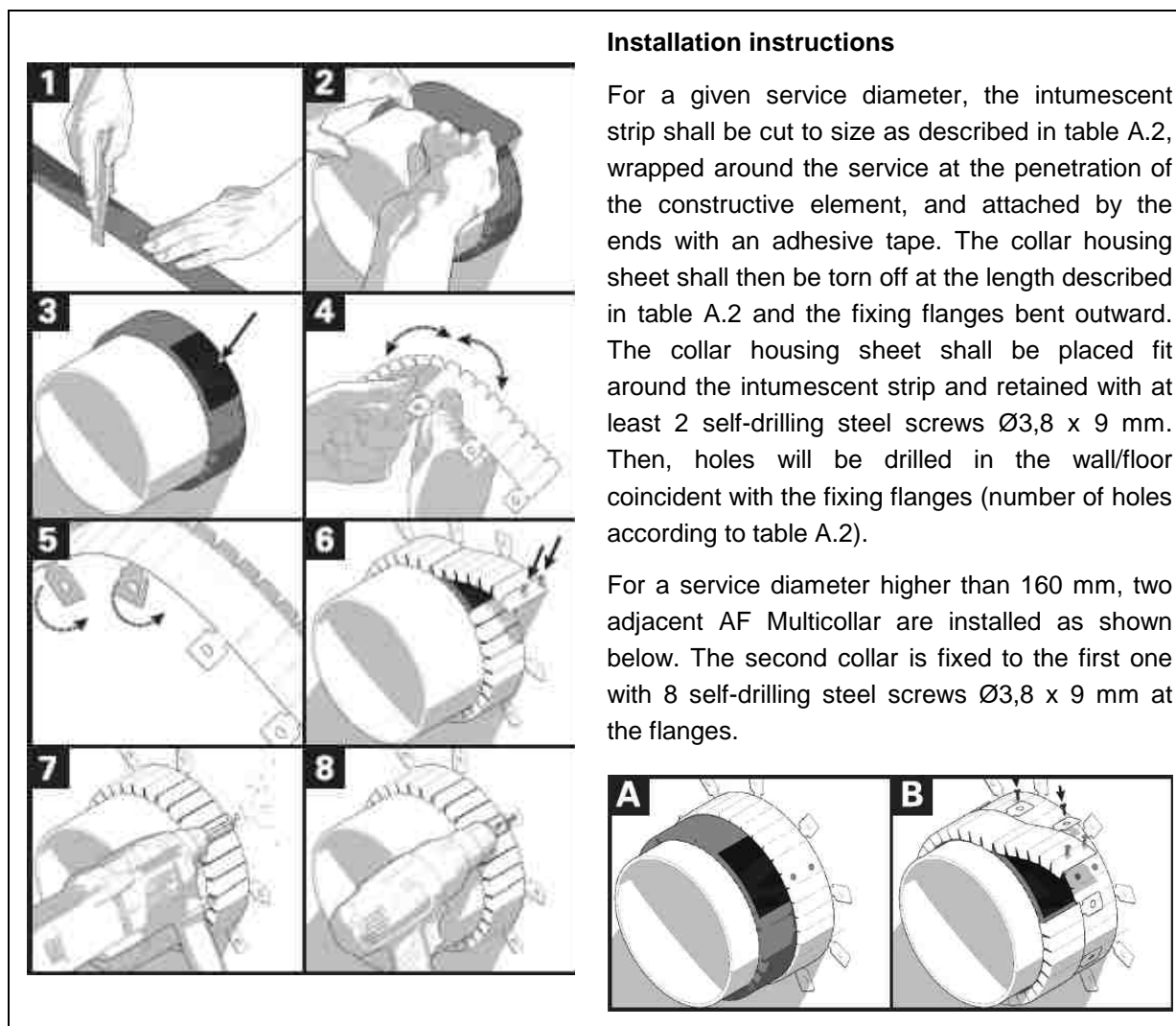

**Figure A.3:** Sequence of AF Multicollar installation.

AF Multicollar shall be fixed to the constructive element depending on the intended use as follows, unless otherwise specified in Annex B:

- In flexible walls, by means of  $\text{Ø}8 \text{ mm} \times 120 \text{ mm}$  galvanised steel screws at the fire exposed side and  $\text{Ø}8 \times 50 \text{ mm}$  galvanised steel screws at the cold side.
- In rigid walls, at both sides by means of  $\text{Ø}8 \text{ mm} \times 60 \text{ mm}$  galvanised steel class 8.8 expansion anchors.
- In floors, at the bottom side by means of  $\text{Ø}8 \text{ mm} \times 60 \text{ mm}$  galvanised steel class 8.8 expansion anchors.

The number of fixings will be in accordance with table A.2. The number of fixing flanges of the collar housing may be different from the required number of fixings. Fixings will be installed every other flange.

All gaps between penetrations and constructive elements will not be greater than 5 mm and shall be filled in with mortar (floors and rigid walls) or gypsum paste (flexible walls), also spread over the constructive element surface around the collar base.

The minimum distance between services penetrating the wall/floor, as well as the minimum distance between services and the constructive element edge, is 200 mm.

The maximum distance from the constructive element to the adequate service support is 500 mm in case of walls (cold side) and floors (upper side).

The following installation provisions will be noted:

- The installation of the penetration seal will not have an effect on the stability of the adjacent building element, even in the event of fire.
- The structural elements related to the wall/floor in which the penetration seal is incorporated will be designed and fire protected in such a way that no additional mechanical load is imposed on the penetration seal.
- The thermal movements of the pipework will be accommodated in such a way that no resulting load is imposed on the penetration seal.
- The services are fixed to the building element in such a way that no additional mechanical load is imposed on the penetration seal in the event of fire.
- The support of the services is maintained during the required period of resistance to fire.
- Pneumatic dispatch systems, compressed air systems, etc. are switched off in the event of fire.

## **ANNEX B. Resistance to fire performance**

### **B.1. General**

The following intended uses of penetration seal are included in this Annex:

- B.2. Plastic pipes.
  - B.2.1. Plastic pipes passing through a flexible or rigid wall.
  - B.2.2. Plastic pipes passing through a rigid floor.
  - B.2.3. Plastic pipes passing through AF Panel.
  - B.2.4. Plastic pipes installed in corners.
  - B.2.5. Inclined plastic pipes.
  - B.2.6. Group of plastic pipes
- B.3. Plastic pipes with acoustic insulation performance.
  - B.3.1. Plastic pipes passing through a flexible or rigid wall.
  - B.3.2. Plastic pipes passing through a rigid floor.
- B.4. Multilayer composite pipes in rigid walls.
- B.5. Insulated metal pipes.
  - B.5.1. Insulated metal pipes passing through a flexible or rigid wall.
  - B.5.2. Insulated metal pipes passing through a rigid floor.
  - B.5.3. Group of insulated metal pipes passing through a flexible or rigid wall
- B.6. Cables passing through a flexible or rigid wall.

## B.2. Plastic pipes

Regarding the material specification of those services included in this Annex B.2, pipes will be made from:

- PVC-U according to EN 1329-1<sup>8</sup>, EN 1453-1<sup>9</sup> and EN ISO 1452-1<sup>10</sup>.
- PVC-C according to EN 1566-1<sup>11</sup>.
- PP according to EN 1451-1<sup>12</sup>.
- HDPE according to EN 1519-1<sup>13</sup> or EN 12666-1<sup>14</sup>.
- PE according to EN 12201-2<sup>15</sup>, EN 1519-1 and EN 12666-1.
- ABS according to EN 1455-1<sup>16</sup>.
- SAN+PVC according to EN 1565-1<sup>17</sup>.

Regarding the pipe end configuration, according to section 2.2.2 of EAD 350454-00-1104 the following field of application applies:

- a classification given for a configuration U/U is also valid for any other pipe end configuration: C/U, U/C and C/C.
- a classification given for a configuration U/C is also valid for a pipe end configuration C/U and C/C.
- a classification given for a configuration C/U is also valid for a pipe end configuration C/C.
- a classification given for a configuration C/C is only valid for a pipe end configuration C/C.

Definition of the pipe end configuration is given in section 6.3.4 of EN 1366-3.

Regarding the pipe diameter and pipe wall thickness, the rules for the field of direct application of the test results given in EN 1366-3 can be applied, i.e. resistance to fire classification given in this section B.2 is valid between the pipe diameters and pipe wall thicknesses as given in the tables, provided that AF Multicollar is installed in accordance with Annex A.

- 
- <sup>8</sup> EN 1329-1      Plastics piping systems for soil and waste discharge (low and high temperature) within the building structure. Unplasticized poly(vinyl chloride) (PVC-U). Part 1: Specifications for pipes, fittings and the system.
- <sup>9</sup> EN 1453-1      Plastics piping systems with structured wall-pipes for soil and waste discharge (low and high temperature) inside buildings. Unplasticized poly(vinyl chloride) (PVC-U). Part 1: Specifications for pipes and the system.
- <sup>10</sup> EN ISO 1452-1      Plastics piping systems for water supply and for buried and above-ground drainage and sewerage under pressure. Unplasticized poly(vinyl chloride) (PVC-U). Part 1: General (ISO 1452-1:2009).
- <sup>11</sup> EN 1566-1      Plastics piping systems for soil and waste discharge (low and high temperature) within the building structure. Chlorinated poly(vinyl chloride) (PVC-C). Part 1: Specifications for pipes, fittings and the system.
- <sup>12</sup> EN 1451-1      Plastics piping systems for soil and waste discharge (low and high temperature) within the building structure. Polypropylene (PP). Part 1: Specifications for pipes, fittings and the system.
- <sup>13</sup> EN 1519-1      Plastics piping systems for soil and waste discharge (low and high temperature) within the building structure. Polyethylene (PE). Part 1: Specifications for pipes, fittings and the system.
- <sup>14</sup> EN 12666-1      Plastics piping systems for non-pressure underground drainage and sewerage. Polyethylene (PE). Part 1: Specifications for pipes, fittings and the system.
- <sup>15</sup> EN 12201-2      Plastics piping systems for water supply, and for drainage and sewerage under pressure. Polyethylene (PE). Part 2: Pipes.
- <sup>16</sup> EN 1455-1      Plastics piping systems for soil and waste discharge (low and high temperature) within the building structure. Acrylonitrile-butadiene-styrene (ABS). Part 1: Requirements for pipes, fittings and the system.
- <sup>17</sup> EN 1565-1      Plastics piping systems for soil and waste discharge (low and high temperature) within the building structure. Styrene copolymer blends (SAN+PVC). Part 1: Specifications for pipes, fittings and the system.

### B.2.1. Plastic pipes passing through a flexible or rigid wall

The flexible or rigid wall shall meet the specification given in section 2 of this ETA.

The relevant size of AF Multicollar will be installed, in accordance with Annex A and the pipe diameter specified in tables B.2.1.1 to B.2.1.3, at both sides of the wall as shown in figure B.2.1.1.

The resistance to fire of the sealed combustible pipes is given in tables B.2.1.1 to B.2.1.3.

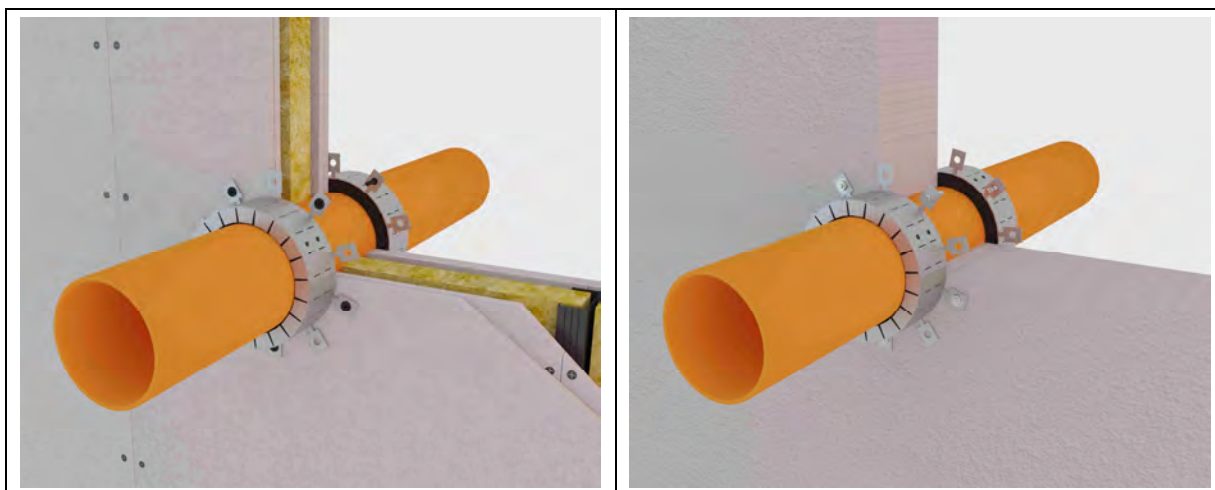

**Figure B.2.1.1:** Example of plastic pipe penetration seal in a flexible or rigid wall.

**Table B.2.1.1:** PVC pipes.

External pipe diameter [Ø] (mm)	Pipe wall thickness [t]		Resistance to fire class
	t <sub>min</sub> (mm)	t <sub>max</sub> (mm)	
≤ 110	3,2	8,1	EI 120 U/U EI 180 U/C <sup>18</sup>
110 < Ø ≤ 160	3,2	9,5 11,0	EI 120 U/U EI 180 U/C <sup>18</sup>
160 < Ø ≤ 250	6,2	18,4	EI 120 U/C

**Table B.2.1.2:** PP pipes.

External pipe diameter [Ø] (mm)	Pipe wall thickness [t]		Resistance to fire class
	t <sub>min</sub> (mm)	t <sub>max</sub> (mm)	
≤ 110	2,7	15,1	EI 120 U/U
110 < Ø ≤ 160	3,9	14,6	EI 120 U/C
160 < Ø ≤ 250	7,7	16,0	EI 120 U/C

<sup>18</sup> Resistance to fire classification only valid for rigid walls of minimum thickness 150 mm.

**Table B.2.1.3:** HDPE, PE, ABS and SAN+PVC pipes.

External pipe diameter [Ø] (mm)	Pipe wall thickness [t]		Resistance to fire class
	t <sub>min</sub> (mm)	t <sub>max</sub> (mm)	
≤ 110	4,2	12,3	EI 120 U/U
	10,5	10,5	EI 120 U/C <sup>19</sup>
110 < Ø ≤ 160	6,2	16,0	EI 120 U/C
	16,0	16,0	EI 120 U/C <sup>19</sup>
160 < Ø ≤ 250	7,7	22,7	EI 120 U/C

### B.2.2. Plastic pipes passing through a rigid floor

The rigid floor shall meet the specification given in section 2 of this ETA.

The relevant size of AF Multicollar will be installed, in accordance with Annex A and the pipe diameter specified in tables B.2.2.1 to B.2.2.3, at the bottom side of the floor as shown in figure B.2.2.1.

The resistance to fire of the sealed combustible pipes is given in tables B.2.2.1 to B.2.2.3.

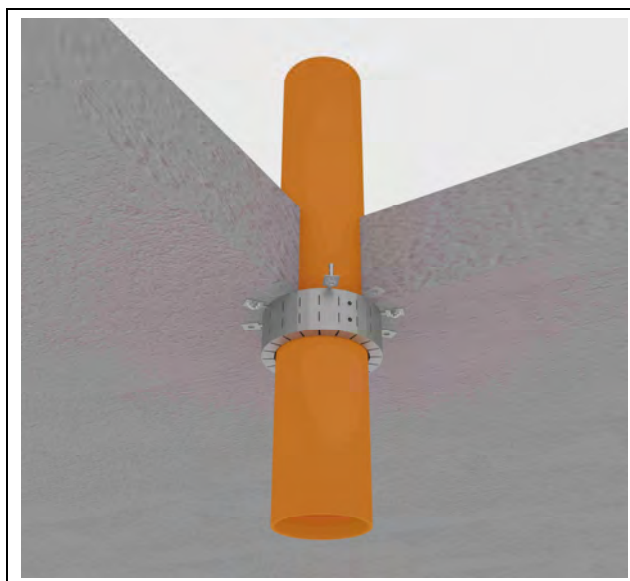

**Figure B.2.2.1:** Example of plastic pipe penetration seal in a rigid floor.

<sup>19</sup> Resistance to fire classification valid for walls of minimum thickness 125 mm with one AF Multicollar at the fire exposed side only. AF SEAL W acrylic sealant shall be applied around the pipe at the cold side of the wall to seal the joint. The maximum distance from the wall to service support will be 150 mm.

**Table B.2.2.1:** PVC pipes.

External pipe diameter [Ø] (mm)	Pipe wall thickness [t]		Resistance to fire class
	t <sub>min</sub> (mm)	t <sub>max</sub> (mm)	
≤ 110	3,2	8,1	EI 180 U/U
110 < Ø ≤ 160	3,2	11,8	EI 180 U/C
160 < Ø ≤ 250	6,2	18,4	EI 180 U/C <sup>20</sup>

**Table B.2.2.2:** PP pipes.

External pipe diameter [Ø] (mm)	Pipe wall thickness [t]		Resistance to fire class
	t <sub>min</sub> (mm)	t <sub>max</sub> (mm)	
≤ 110	2,7	2,7	EI 180 U/U
	15,1	15,1	EI 120 U/U
110 < Ø ≤ 160	3,9	14,6	EI 180 U/C
160 < Ø ≤ 250	8,8	22,7	EI 180 U/C <sup>21</sup>

**Table B.2.2.3:** HDPE, PE, ABS and SAN+PVC pipes.

External pipe diameter [Ø] (mm)	Pipe wall thickness [t]		Resistance to fire class
	t <sub>min</sub> (mm)	t <sub>max</sub> (mm)	
≤ 110	4,2	15,1	EI 180 U/U
110 < Ø ≤ 160	6,2	21,9	EI 180 U/C
160 < Ø ≤ 250	8,2	22,7	EI 180 U/C <sup>22</sup>

### B.2.3. Plastic pipes passing through AF PANEL

#### B.2.3.1. Resistance to fire performance

The resistance to fire performance given in section B.2.1 and section B.2.2 for plastic pipes protected with AF Multicollar are also valid when the pipe penetrates a double layer of AF PANEL, as described in B.2.3.2, which shuts an opening in the constructive element meeting the specification given in section 2 of this ETA (rigid floors with a minimum density of 1600 kg/m<sup>3</sup>).

#### B.2.3.2. Description of AF PANEL

AF PANEL is a rock wool panel of density 150 kg/m<sup>3</sup> and thickness 50 mm, coated on both faces with 1 mm thickness of the acrylic ablative coating AF SEAL T (AF PANEL total thickness of 52 mm).

Two layers of AF PANEL are installed levelled to the constructive element surfaces as shown in figures B.2.3.1 and B.2.3.2. AF PANEL is installed tightly fitted by pressure to the constructive element without

<sup>20</sup> Performance valid for a rigid floor with a minimum density of 1600 kg/m<sup>3</sup>.

<sup>21</sup> For a pipe wall thickness 8,8 mm, the given performance is valid for a rigid floor with a minimum density of 1600 kg/m<sup>3</sup>.

<sup>22</sup> For a pipe wall thickness 8,2 mm, the given performance is valid for a rigid floor with a minimum density of 1600 kg/m<sup>3</sup>.



mechanical fixing (in the case of flexible walls, a frame of steel C-profiles of (50 x 69 x 0,6) mm is installed around the opening). AF SEAL W acrylic sealant shall be applied at the joint between the plastic pipe and AF PANEL at both sides of the wall, as well as at the perimeter of AF PANEL in contact with the constructive element.

In the case of walls, the maximum size of the opening shut with AF PANEL is 1750 mm x 1000 mm, with a permitted increase up to either 25 % in height or 25 % in width or 25 % in area in accordance with table A.3 in EN 15882-3<sup>23</sup>. Vertical and horizontal joints can be installed within the panel area. If a blank seal (opening shut with AF PANEL without passing services) is installed, no splices are allowed.

In the case of floors, the maximum size of the opening shut with AF PANEL is 900 mm x 750 mm. Vertical and horizontal joints can be installed within the panel area. If a blank seal (opening shut with AF PANEL without passing services) is installed, no splices are allowed.

More than one plastic pipe can be installed passing through the panels provided that total amount of cross sections of pipes does not exceed the 10 % of the opening area, the distance between pipes is higher than 210 mm and the distance from any pipe to the opening edges is higher than 100 mm.

#### B.2.3.3. Installation of AF Multicollar in walls with an opening shut by AF PANEL

AF Multicollar is fixed at both sides of the wall with steel wires of minimum diameter 1 mm from the collar flanges to the wall, where the wires are fixed by Ø3,5 x 55 mm self-tapping steel screws in flexible walls (fixed to the metal C-profiles frame around the opening) and by expansion anchors Ø8 x 60 mm in rigid walls. The minimum number of wires to fix the collar shall be in accordance with the number of fixings given in table A.2.

AF SEAL W acrylic sealant is applied at an approximate dry thickness of 2 mm over the fire exposed surface of AF PANEL, completely covering the steel wires and their fixing to the constructive element.

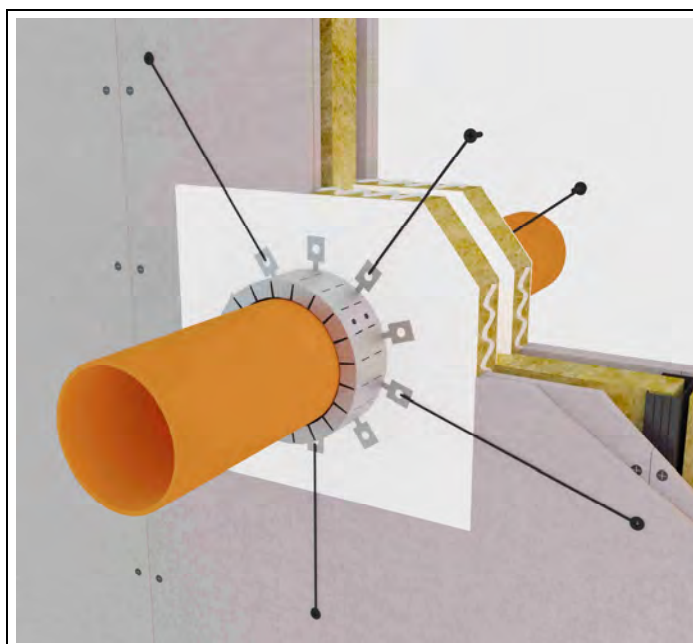

**Figure B.2.3.1:** Example of AF Multicollar fixed with steel wires in walls.

<sup>23</sup> EN 15882-3 Extended applications of results from fire resistance tests for service installations. Part 3: Penetration seals.



#### B.2.3.4. Installation of AF Multicollar in floors with an opening shut by AF PANEL

AF Multicollar is held at the bottom side of the floor with steel wires of minimum diameter 1 mm from all the collar flanges, passing through the double layer of AF PANEL and fixed to a protected supporting structure at the upper side of the floor.

AF SEAL W acrylic sealant is applied at an approximate dry thickness of 2 mm over the fire exposed surface of AF PANEL, completely covering the steel wires.

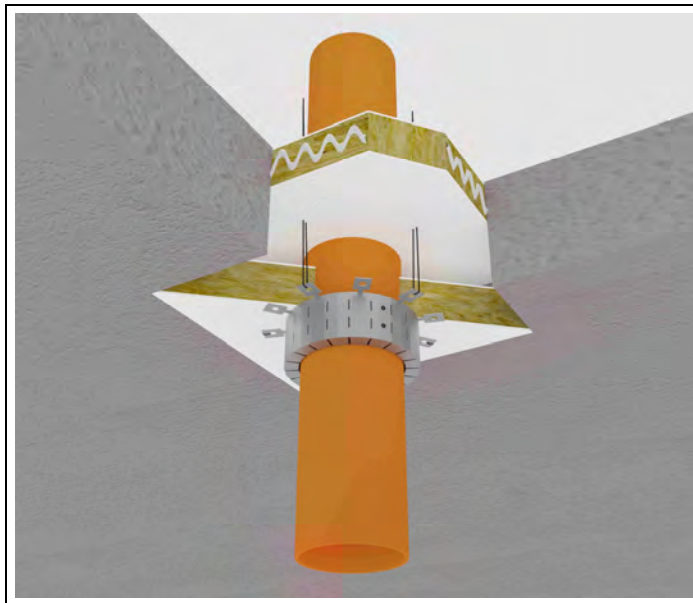

**Figure B.2.3.2:** Example of AF Multicollar fixed with steel wires in floors.

### B.2.4. Plastic pipes installed in corners

#### B.2.4.1. Plastic pipes penetrating a flexible or rigid wall in a corner

The flexible or rigid wall shall meet the specification given in section 2 of this ETA. The constructive elements (floor and wall) adjacent to the wall forming the corner shall have a minimum density of 550 kg/m<sup>3</sup> and a resistance to fire EI 120.

The relevant size of AF Multicollar will be installed, in accordance with Annex A <sup>24</sup> and the pipe diameter specified in table B.2.4.1, at the fire exposed side of the wall as shown in figure B.2.4.1. The pipe shall be in contact with the elements (floor and wall) forming the corner.

The resistance to fire of the sealed combustible pipes is given in table B.2.4.1.

<sup>24</sup> 6 fixings are installed instead of 4 (at least 3 of them shall be fixed in such a position that keeps the collar in direct contact with the pipe along a minimum angle arch of 90°).

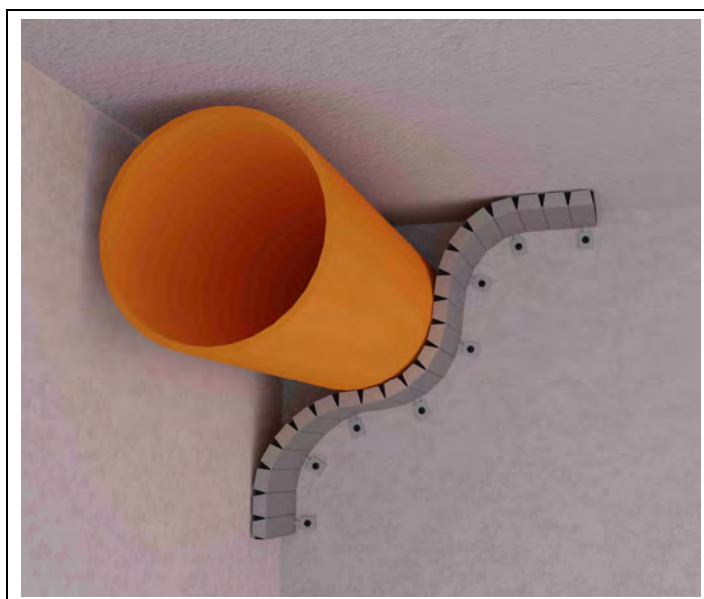

**Figure B.2.4.1:** Example of plastic pipe penetrating a wall in a corner.

**Table B.2.4.1:** HDPE, PE, ABS and SAN+PVC pipes.

External pipe diameter [Ø] (mm)	Pipe wall thickness t (mm)	Resistance to fire class
≤ 110	9,3	EI 120 U/C

#### B.2.4.2. Plastic pipes penetrating a floor in a corner

The floor shall meet the specification given in section 2 of this ETA with a minimum density of 1600 kg/m<sup>3</sup>. The constructive elements (walls) adjacent to the floor forming the corner shall have a minimum density of 520 kg/m<sup>3</sup> and resistance to fire EI 180.

The relevant size of AF Multicollar will be installed, in accordance with Annex A<sup>24</sup> and the pipe diameter specified in table B.2.4.2, at the bottom side of the floor as shown in figure B.2.4.2. The pipe shall be in contact with the elements (walls) forming the corner.

The resistance to fire of the sealed combustible pipes is given in table B.2.4.2.

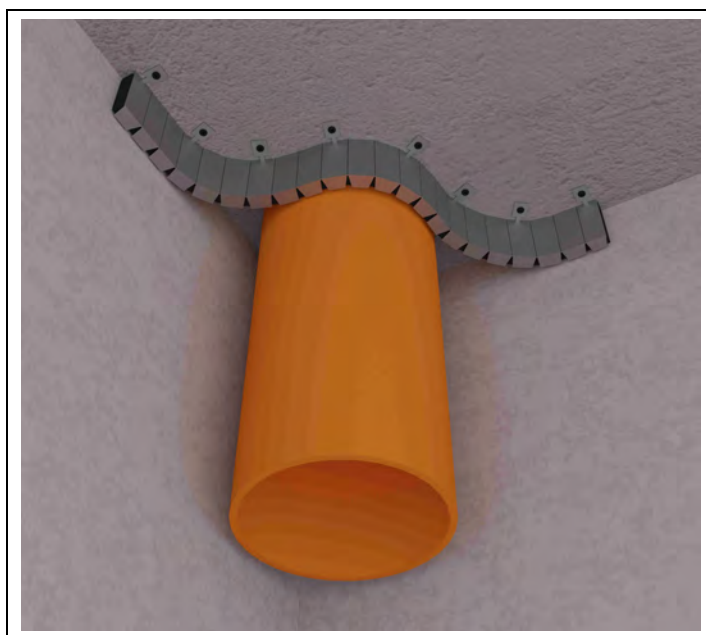

Figure B.2.4.2: Example of plastic pipe penetrating a floor in a corner.

Table B.2.4.2: HDPE, PE, ABS and SAN+PVC pipes.

External pipe diameter [Ø] (mm)	Pipe wall thickness t (mm)	Resistance to fire class
≤ 110	8,1	EI 180 U/C

## B.2.5. Inclined plastic pipes

### B.2.5.1. Inclined plastic pipes passing through a flexible or rigid wall

The flexible or rigid wall shall meet the specification given in section 2 of this ETA.

The relevant size of AF Multicollar will be installed, in accordance with Annex A<sup>25</sup> and the pipe diameter specified in tables B.2.5.1.1 to B.2.5.1.3, at both sides of the wall as shown in figure B.2.5.1.1. Pipes are installed parallel to the floor and at any angle from 90° to 45° in relation to the wall plane. AF Multicollar will be closely fitted around the inclined pipe.

The resistance to fire of the sealed inclined combustible pipes is given in tables B.2.5.1.1 to B.2.5.1.3.

<sup>25</sup> Except for the housing length and inlay strip length which will be increased to cover the pipe inclined position in accordance with the manufacturer's installation instructions.

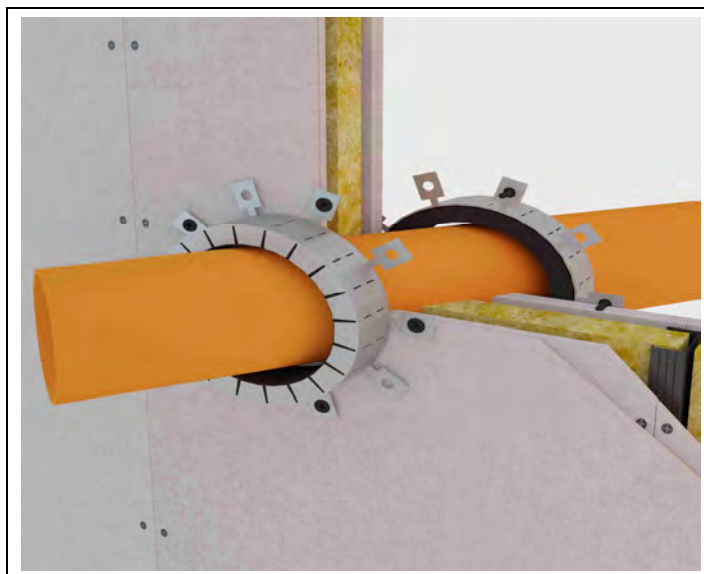

**Figure B.2.5.1.1:** Example of inclined plastic pipe penetration seal in a flexible wall.

**Table B.2.5.1.1:** PVC pipes.

External pipe diameter [Ø] (mm)	Pipe wall thickness [t]		Resistance to fire class
	t <sub>min</sub> (mm)	t <sub>max</sub> (mm)	
≤ 110	3,2	8,1	EI 120 U/U
110 < Ø ≤ 160	3,2	9,5	EI 120 U/C

**Table B.2.5.1.2:** PP pipes.

External pipe diameter [Ø] (mm)	Pipe wall thickness [t]		Resistance to fire class
	t <sub>min</sub> (mm)	t <sub>max</sub> (mm)	
≤ 110	2,7	10,0	EI 120 U/C
110 < Ø ≤ 160	3,9	14,6	EI 120 U/C

**Table B.2.5.1.3:** HDPE, PE, ABS and SAN+PVC pipes.

External pipe diameter [Ø] (mm)	Pipe wall thickness [t]		Resistance to fire class
	t <sub>min</sub> (mm)	t <sub>max</sub> (mm)	
≤ 110	4,2	12,3	EI 120 U/C
110 < Ø ≤ 160	6,2	16,0	EI 120 U/C

### B.2.5.2. Inclined plastic pipes passing through a rigid floor

The rigid floor shall meet the specification given in section 2 of this ETA with a minimum density of 1600 kg/m<sup>3</sup>.

The relevant size of AF Multicollar will be installed, in accordance with Annex A<sup>26</sup> and the pipe diameter specified in table B.2.5.2.1, at the bottom side of the floor as shown in figure B.2.5.2.1. Pipes are installed at any angle from 90° to 45° in relation to the floor plane. AF Multicollar will be closely fitted around the inclined pipe.

The resistance to fire of the sealed inclined combustible pipes is given in table B.2.5.2.1.

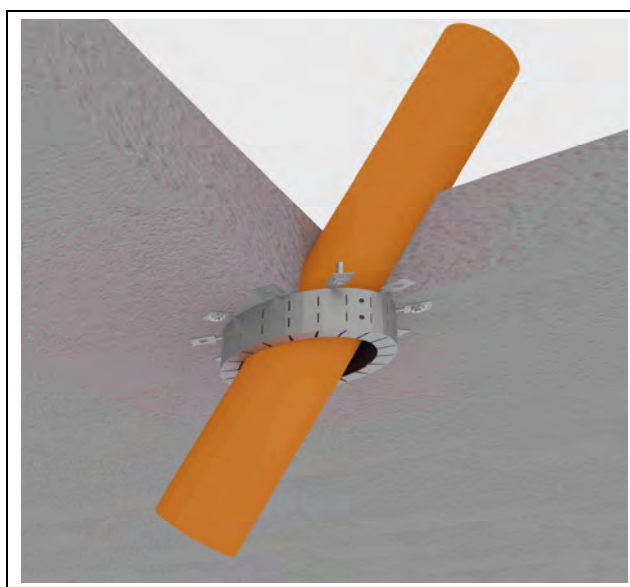

**Figure B.2.5.2.1:** Example of inclined plastic pipe penetration seal in a floor.

**Table B.2.5.2.1:** PVC pipes.

External pipe diameter [Ø] (mm)	Pipe wall thickness [t]		Resistance to fire class
	t <sub>min</sub> (mm)	t <sub>max</sub> (mm)	
110 < Ø ≤ 160	3,2	11,8	EI 180 U/C

<sup>26</sup> Except for the housing length and inlay strip length which will be increased to cover the pipe inclined position in accordance with the manufacturer's installation instructions. In addition, 10 expansion anchors are used to fix the collar.

## B.2.6. Group of plastic pipes

### B.2.6.1. Group of plastic pipes passing through a flexible or rigid wall

The flexible or rigid wall shall meet the specification given in section 2 of this ETA.

The relevant size of AF Multicollar will be installed, in accordance with Annex A<sup>27</sup> and the external dimensions (110 mm x 330 mm) of the group of pipes as shown in figure B.2.6.1.1.

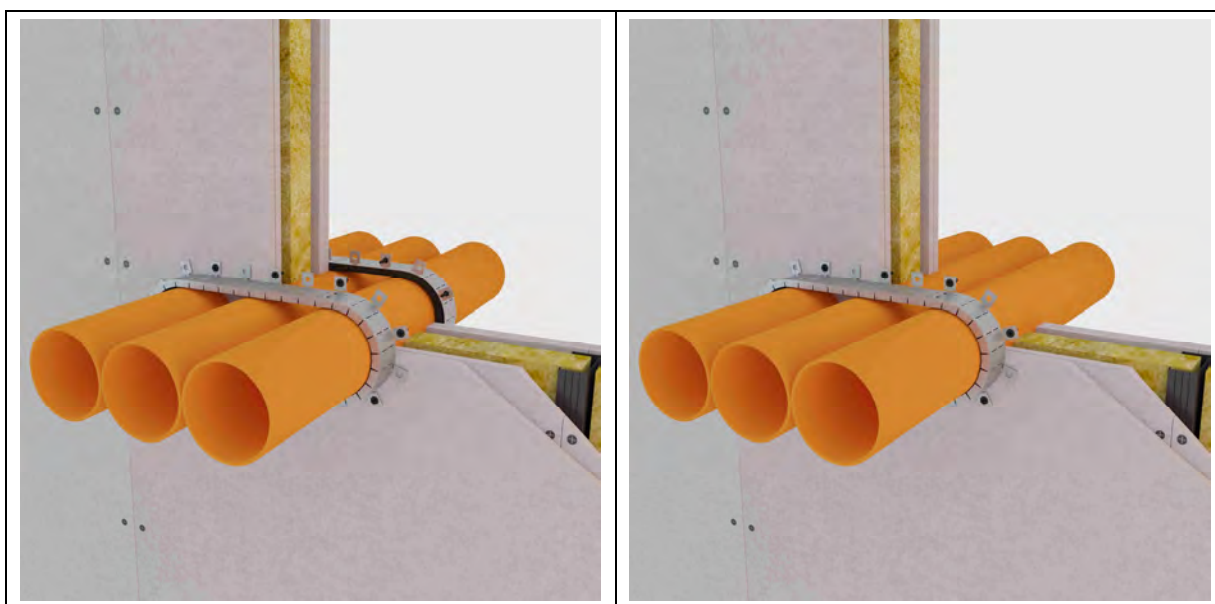

**Figure B.2.6.1.1:** Example of plastic pipes group penetration seal in a flexible wall:  
(a) at both sides of the wall, (b) at the fire exposed side only.

**Table B.2.6.1.1:** Group of pipes.

Type	External pipe diameter [Ø] (mm)	Pipe wall thickness [t]	
		t <sub>min</sub> (mm)	t <sub>max</sub> (mm)
PVC	≤ 110	3,2	3,2
PP		2,7	2,7
HDPE		4,2	9,3

The plastic pipes will be adjacent to each other (no gap between services). The number of pipes can be reduced. AF Multicollar is installed closely fitted around the pipes and the number of intumescent strip layers is 5 for a total intumescent thickness of 20 mm.

The resistance to fire of the sealed plastic pipes group is EI 120 U/U when AF Multicollar is installed at both sides of the wall and EI 120 U/C when AF Multicollar is installed at the fire exposed side only.

<sup>27</sup> AF Multicollar with b = 20 mm (b in table A.2, 5 layers of intumescent strip), 8 fixings, housing length 950 mm and inlay strip length 4300 mm.

### B.2.6.2. Group of plastic pipes passing through a rigid floor

The rigid floor shall meet the specification given in section 2 of this ETA with a minimum density of 1600 kg/m<sup>3</sup>.

The relevant size of AF Multicollar will be installed, at the bottom side of the floor, in accordance with Annex A<sup>28</sup> and the external dimensions (110 mm x 330 mm) of the group of pipes as shown in figure B.2.6.2.1.

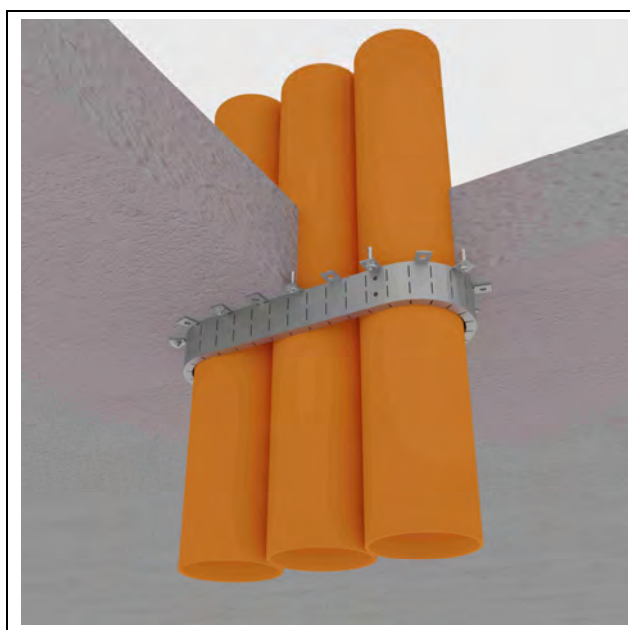

**Figure B.2.6.2.1:** Example of plastic pipes group penetration seal in a floor.

**Table B.2.6.2.1:** Group of pipes.

Type	External pipe diameter [Ø] (mm)	Pipe wall thickness [t]	
		t <sub>min</sub> (mm)	t <sub>max</sub> (mm)
PVC	≤ 110	3,2	3,2
PP		2,7	7,2
HDPE		6,2	10,0

The plastic pipes will be adjacent to each other (no gap between services). The number of pipes can be reduced. AF Multicollar is installed closely fitted around the pipes and the number of intumescent strip layers is 5 for a total intumescent thickness of 20 mm.

The resistance to fire of the sealed plastic pipes group is EI 180 U/C.

<sup>28</sup> AF Multicollar with b = 20 mm (b in table A.2, 5 layers of intumescent strip), 8 fixings, housing length 950 mm and inlay strip length 4300 mm.



### B.3. Plastic pipes with acoustic insulation performance

#### B.3.1. Plastic pipes passing through a flexible or rigid wall

The flexible or rigid wall shall meet the specification given in section 2 of this ETA.

The relevant size of AF Multicollar will be installed, in accordance with Annex A and the pipe diameter specified in table B.3.1, at both sides of the wall as shown in figure B.3.1.

The resistance to fire of the sealed combustible pipes with acoustic insulation performance, as listed in table B.3.1 or equivalent, is EI 120 U/C.

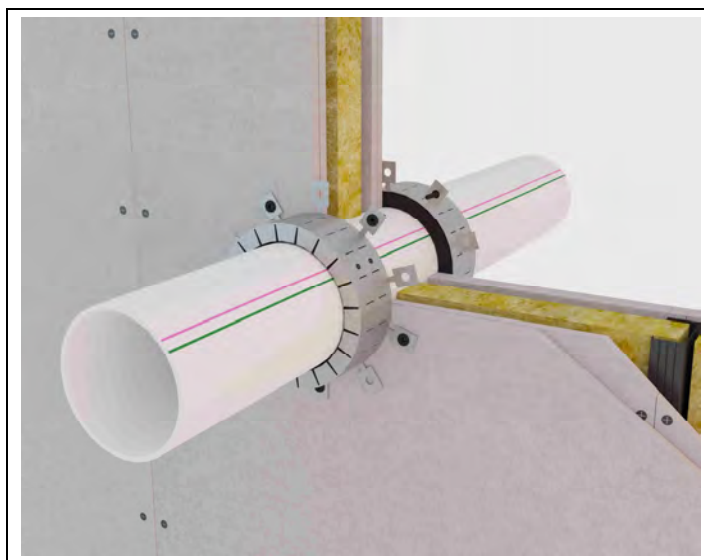

**Figure B.3.1:** Example of acoustic plastic pipe penetration seal in a flexible wall.

**Table B.3.1:** Plastic pipes with acoustic insulation performance.

Type of pipe	External pipe diameter [Ø] (mm)	Pipe wall thickness t (mm)
PVC-U pipe type FRIAPHON of Girpi	≤ 110	6,0
Mineral reinforced PP type SiTech+ of Wavin		3,4
Mineral reinforced PP-MD type RAUPIANO PLUS of Rehau		2,5
Mineral fibers reinforced PE-S2 type Silent-DB20 of Geberit		6,0
Mineral reinforced PP type ASTO of Wavin		6,0
Mineral fibers reinforced PP MX type Silent-Pro of Geberit		6,0



### B.3.2. Plastic pipes passing through a rigid floor

The rigid floor shall meet the specification given in section 2 of this ETA with a minimum density of 1600 kg/m<sup>3</sup>.

The relevant size of AF Multicollar will be installed, in accordance with Annex A and the pipe diameter specified in table B.3.2, at the bottom side of the floor as shown in figure B.3.2.

The resistance to fire of the sealed combustible pipes with acoustic insulation performance for drainage systems, as listed in table B.3.2 or equivalent, is EI 180 U/C.

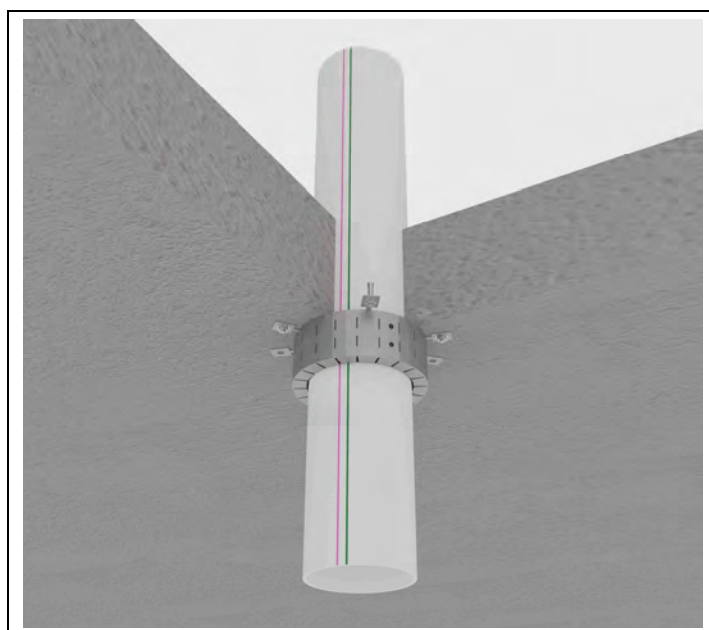

**Figure B.3.2:** Example of acoustic plastic pipe penetration seal in a floor.

**Table B.3.2:** Plastic pipes with acoustic insulation performance.

Type of pipe	External pipe diameter [Ø] (mm)	Pipe wall thickness t (mm)
PVC-U pipe type FRIAPHON of Girpi	≤ 110	6,0
Mineral reinforced PP type SiTech+ of Wavin		3,4
Mineral reinforced PP-MD type RAUPIANO PLUS of Rehau		2,5
Mineral fibers reinforced PE-S2 type Silent-DB20 of Geberit		6,0
Mineral reinforced PP type ASTO of Wavin		5,3
Mineral fibers reinforced PP MX type Silent-Pro of Geberit		4,2

#### B.4. Multilayer composite pipes passing through a rigid wall

The rigid wall shall meet the specification given in section 2 of this ETA with a minimum thickness of 150 mm.

The relevant size of AF Multicollar will be installed, in accordance with Annex A and the external diameter of the service installation as described below, at the fire exposed side of the wall as shown in figure B.4.1.

The service installation is formed by a bundle of multilayer composite pipes as specified in table B.4.1. Every single pipe is insulated according to table B.4.2.

**Table B.4.1:** Bundle of multilayer composite pipes.

Material	External pipe diameter (mm)	Pipe wall thickness (mm)	Quantity	Overall installation diameter (mm)
PE-Xb / Al / HDPE	20	3	2	110
	16	2	8	

**Table B.4.2:** Individual pipe insulation.

Material	Internal insulation diameter (mm)	Insulation thickness (mm)	Density (kg/m <sup>3</sup> )	Reaction to fire
PE	20	7	50	E
	16			

The number of insulated multilayer pipes can be reduced, always installed in contact each other, provided that the collar size is adjusted in accordance with table A.2, for AF Multicollar internal diameter between 30 mm and 110 mm, to closely fit around the pipes bundle. All gaps between the multilayer pipes bundle and the wall, as well as the gaps between the pipes bundle and AF Multicollar, will be filled with mortar.

The resistance to fire of the sealed bundle of multilayer composite pipes is EI 180 U/C.

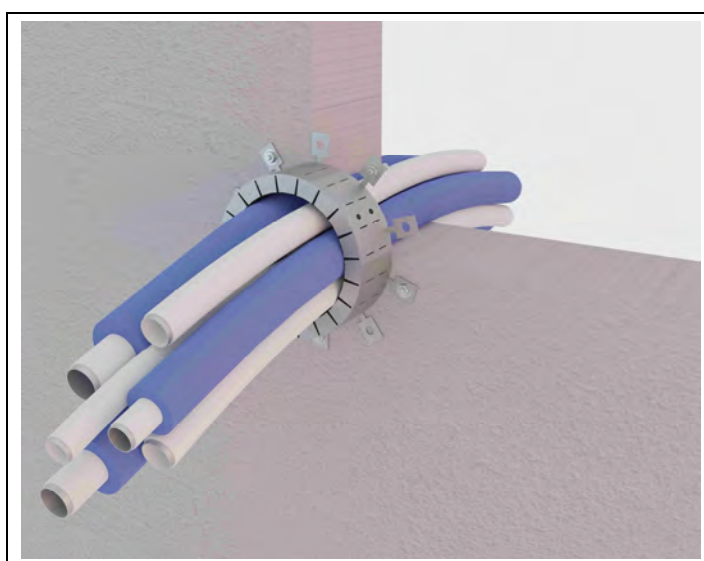

**Figure B.4.1:** Example of multilayer composite pipes penetration seal in a rigid wall.

## B.5. Insulated metal pipes

### B.5.1. Insulated metal pipes passing through a flexible or rigid wall

The flexible or rigid wall shall meet the specification given in section 2 of this ETA.

The metal pipe will be made of steel with a minimum melting point of 1450 °C and a maximum thermal conductivity of 52 W/(mK).

The type of foamed elastomeric insulation material will be as follows:

- Continuous insulation.
- Reaction to fire: from B<sub>L</sub>-s1,d0 to D<sub>L</sub>-s3,d0.
- Maximum thermal conductivity (23 °C):  $\lambda \leq 0,043$  W/(mK).
- Assessed types of foamed elastomeric insulation material: Armaflex Ultima, Armaflex ACE.

The relevant size of AF Multicollar will be installed in accordance with Annex A, the insulated pipe overall diameter specified in table B.5.1.1 and the dimensions given in table B.5.1.2, at the fire exposed side of the wall as shown in figure B.5.1.

**Table B.5.1.1:** Dimensions of the insulated metal pipes.

Metal pipe		Insulation thickness (mm)	AF Multicollar
External diameter (mm)	Wall thickness (mm)		
20	1	9	AF Multicollar 38
	6		
	1	60	AF Multicollar 140
	6		
200	1,2	19	AF Multicollar 238
	9		
	1,2	60	AF Multicollar 320
	9		

**Table B.5.1.2:** Dimensions of AF Multicollar (installed)for sealing of insulated metal pipes.

Type	d (mm)	D (mm)	H (mm)	b (mm)	N° of strip layers	N° of fixings	Housing length (mm)	Inlay strip length (mm)
AF Multicollar 38	38	47	50	4	1	3	168	144
AF Multicollar 140	140	165	50	12	3	5	560	1450
AF Multicollar 238	238	247	50	4	1	5	796	773
AF Multicollar 320	320	345	50	12	3	5	1100	3165

Notes:

- d, D, H and b refer to the dimensions of the collar once installed (see figure A.2).
- Housing length and inlay strip length refer to the dimensions of the components to be cut for installation.

The rules for the field of direct application of the test results given in EN 1366-3 can be applied regarding the diameter and wall thickness of the metal pipe and the insulation thickness, provided that the collar dimensions are adjusted to closely fit around the insulation and the ratio (insulation thickness / inlay intumescent thickness<sup>29</sup>) is 4 as maximum. This condition (ratio) does not apply to the dimensions given in table B.5.1.2, only to the intermediate dimensions from interpolation.

The resistance to fire of the sealed insulated metal pipe is EI 120 C/C.

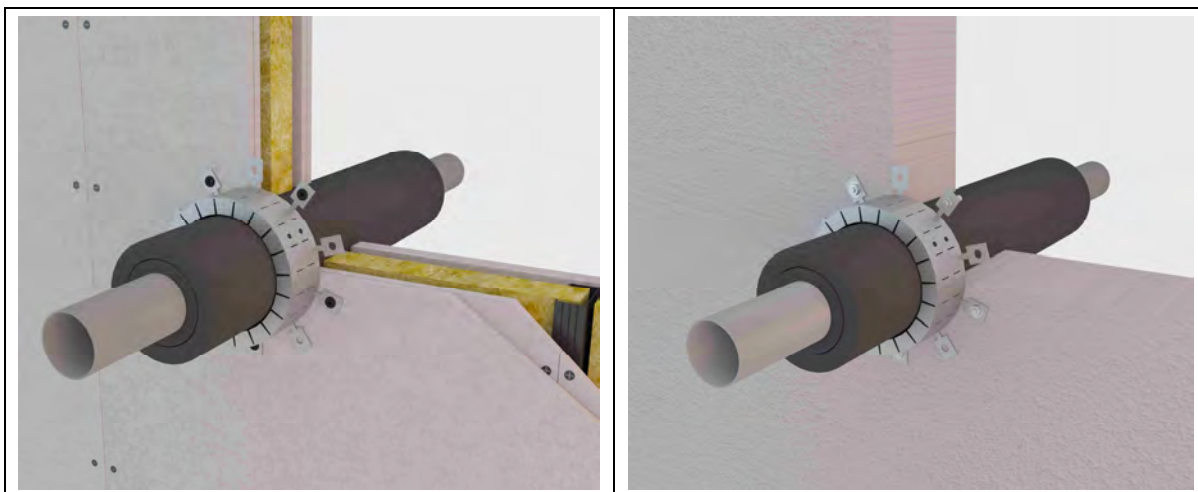

**Figure B.5.1:** Example of insulated metal pipe penetration seal in a flexible and rigid wall.

### B.5.2. Insulated metal pipes passing through a rigid floor

The rigid floor shall meet the specification given in section 2 of this ETA with a minimum density of 1600 kg/m<sup>3</sup>.

The metal pipe will be made of steel with a minimum melting point of 1450 °C and a maximum thermal conductivity of 52 W/(mK).

The type of foamed elastomeric insulation material will be as follows:

- Continuous insulation.
- Reaction to fire: from B<sub>L</sub>-s1,d0 to D<sub>L</sub>-s3,d0.
- Maximum thermal conductivity (23 °C):  $\lambda \leq 0,043$  W/(mK).
- Assessed types of foamed elastomeric insulation material: Armaflex Ultima, Armaflex ACE.

The relevant size of AF Multicollar will be installed in accordance with Annex A, the insulated pipe overall diameter specified in table B.5.2.1 and the dimensions given in table B.5.2.2, at the bottom side of the floor as shown in figure B.5.2.

<sup>29</sup> Inlay intumescent thickness: b in tables A.2 and B.5.1.2.

**Table B.5.2.1:** Dimensions of the insulated metal pipes.

Metal pipe		Insulation thickness (mm)	AF Multicollar
External diameter (mm)	Wall thickness (mm)		
20	1	9	AF Multicollar 38
	6		
	1	60	AF Multicollar 140
	6		
200	1,2	19	AF Multicollar 238
	9		
	1,2	60	AF Multicollar 320
	9		

**Table B.5.2.2:** Dimensions of AF Multicollar (installed) for sealing of insulated metal pipes.

Type	d (mm)	D (mm)	H (mm)	b (mm)	N° of strip layers	N° of fixings	Housing length (mm)	Inlay strip length (mm)
AF Multicollar 38	38	47	50	4	1	3	168	144
AF Multicollar 140	140	165	50	12	3	5	560	1450
AF Multicollar 238	238	247	50	4	1	5	796	773
AF Multicollar 320	320	345	50	12	3	5	1100	3165

Notes:

- d, D, H and b refer to the dimensions of the collar once installed (see figure A.2).
- Housing length and inlay strip length refer to the dimensions of the components to be cut for installation.

The rules for the field of direct application of the test results given in EN 1366-3 can be applied regarding the diameter and wall thickness of the metal pipe and the insulation thickness, provided that the collar dimensions are adjusted to closely fit around the insulation and the ratio (insulation thickness / inlay intumescent thickness<sup>30</sup>) is 4 as maximum. This condition (ratio) does not apply to the dimensions given in table B.5.2.2, only to the intermediate dimensions from interpolation.

The resistance to fire of the sealed insulated metal pipe is EI 180 C/C.

<sup>30</sup> Inlay intumescent thickness: b in tables A.2 and B.5.2.2.

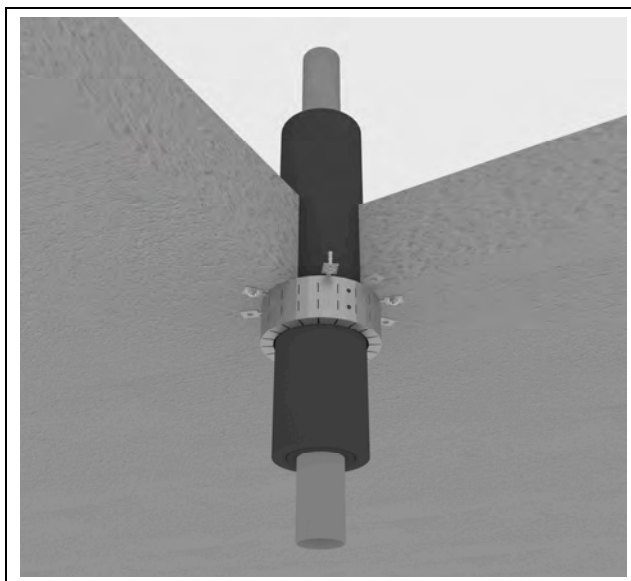
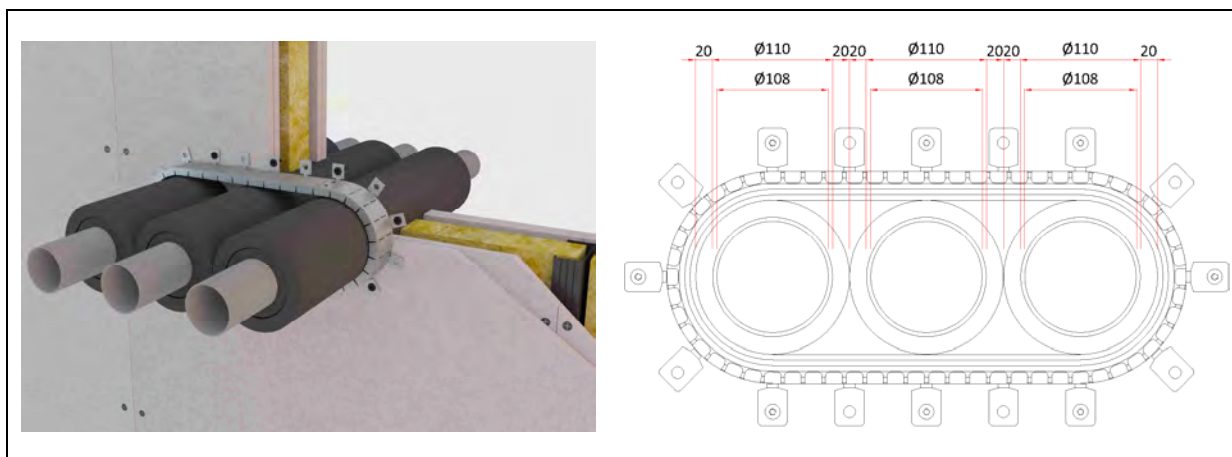

**Figure B.5.2:** Example of insulated metal pipe penetration seal in a floor.

**B.5.3. Group of insulated metal pipes passing through a flexible or rigid wall**

The flexible or rigid wall shall meet the specification given in section 2 of this ETA.

The relevant size of AF Multicollar will be installed, at the fire exposed side of the wall, in accordance with Annex A<sup>31</sup> and the external dimensions (148 mm x 444 mm) of the group of insulated metal pipes as shown in figure B.5.3.



**Figure B.5.3:** Example of insulated metal pipes group penetration seal in a flexible wall.

The metal pipes will be made of steel with a minimum melting point of 1450 °C and a maximum thermal conductivity of 52 W/(mK), with external diameter between 20 mm and 108 mm and wall thickness 4 mm (every pipe).

<sup>31</sup> AF Multicollar with b = 12 mm (b in table A.2, 3 layers of intumescent strip), 8 fixings, housing length 1170 mm and inlay strip length 3350 mm.

The type of foamed elastomeric insulation material will be as follows:

- Continuous insulation.
- Thickness: 20 mm.
- Reaction to fire: D<sub>L</sub>-s3,d0.
- Density: 50 kg/m<sup>3</sup>.
- Maximum thermal conductivity (23 °C):  $\lambda \leq 0,039$  W/(mK).
- Assessed type of insulation material: Armaflex ACE.

The insulated metal pipes will be adjacent to each other (no gap between services). The number of pipes can be reduced. AF Multicollar is installed closely fitted around the insulated pipes and the number of intumescent strip layers is 3 for a total intumescent thickness of 12 mm.

The resistance to fire of the sealed insulated metal pipes group is EI 120 C/C.

## B.6. Cables passing through a flexible or rigid wall

The flexible or rigid wall shall meet the specification given in section 2 of this ETA.

The cables shall be of the type “small sheathed cables” (Group 1 according to Annex A of EN 1366-3):

- 10 cables A1 model “5×1,5 mm<sup>2</sup> CI 1 PVC/PVC 600/1000V NYYJ”.
- 10 cables A2 model “5×1,5 mm<sup>2</sup> CI 5 Cu EPR/PCP 450/750V H07RN-F”.
- 10 cables A3 model “5×1,5 mm<sup>2</sup> CI 1 Cu XLPE/LSZH 600/1000V N2XH-J”.
- 2 cables B model “1×95 mm<sup>2</sup> CI 2 PVC/PVC 600/1000V NYY0”.

The cables shall be in accordance with section A.3.1.1<sup>32</sup> of EN 1366-3 with a maximum cable diameter of 21 mm. The cables will be installed kept together.

The relevant size of AF Multicollar will be installed, at the fire exposed side of the wall as shown in figure B.6.1, in accordance with Annex A up to a maximum overall diameter of the cables bundle of 110 mm (AF Multicollar 110). The number of cables can be reduced, provided that the collar size is adjusted in accordance with table A.2 (AF Multicollar 30 to AF Multicollar 110) to closely fit around the cables bundle.

The resistance to fire of the sealed cables is EI 120.

In the case of a rigid wall of minimum thickness of 150 mm and resistance to fire EI 180, the resistance to fire of the sealed cables as described above is EI 180.



**Figure B.6.1:** Example of small sheathed cables penetration seal in a flexible or rigid wall.

<sup>32</sup> EN 1366-3, A.3.1.1: All cable types currently and commonly used in building practice in Europe except non-sheathed cables (wires), tied bundles and waveguides; optical fibre cables are covered.